

(No Model.)

J. E. WALCOTT.

DEVICE FOR FINISHING CHAIN SWIVELS.

No. 295,843.

Patented Mar. 25, 1884.

Fig. 4.



Fig. 6.

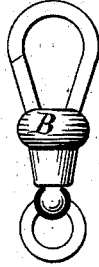

Fig. 5.



Fig. 1.

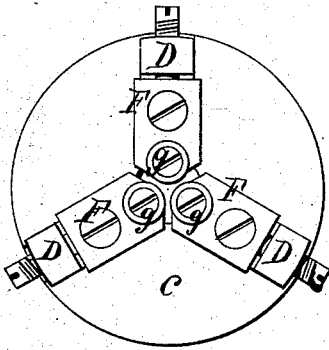

Fig. 2.

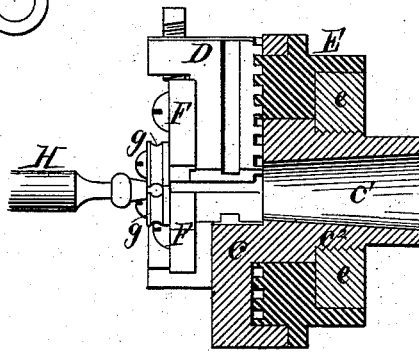

Fig. 3.

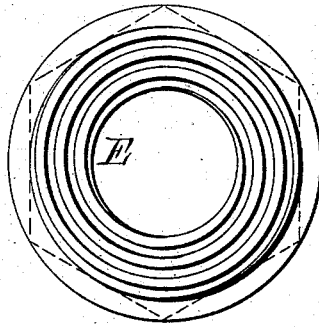

Fig. 7.



WITNESSES:

Wm. L. Cook
C. H. Leathers

INVENTOR:

James E. Walcott
by Joseph A. Miller
Att'y

UNITED STATES PATENT OFFICE.

JABEZ E. WALCOTT, OF PROVIDENCE, RHODE ISLAND, ASSIGNOR TO FREDERICK I. MARCY, OF SAME PLACE.

DEVICE FOR FINISHING CHAIN-SWIVELS.

SPECIFICATION forming part of Letters Patent No. 295,843, dated March 25, 1884.

Application filed November 13, 1882. (No model.)

To all whom it may concern:

Be it known that I, JABEZ E. WALCOTT, of the city and county of Providence, and State of Rhode Island, have invented a new and useful Improvement in Process of and Chucks for Finishing Chain-Swivels; and I hereby declare that the following is a full, clear, and exact description of the same, reference being had to the accompanying drawings, forming part of this specification.

This invention has reference to an improvement in chucks for spinning and finishing the columns of the chain-swivels; and it consists in the peculiar and novel construction of the chuck and adaptation for the purpose of finishing the columns of chain-swivels, as will be more fully set forth hereinafter.

Figure 1 is a face view of my improved chuck. Fig. 2 is a sectional view of the same. Fig. 3 is a view of the helix by which the dogs are operated. Fig. 4 is a view of the partially-drawn column. Fig. 5 is a view of a spun-column. Fig. 6 is a view of the completed chain-swivel. Fig. 7 is a view of a modified spun-column.

The round columns of chain-swivels have heretofore been cast and afterward finished to receive the bow. In this construction large loss of metal is caused in the casting. The turning and finishing is also expensive, and the column is heavier than utility and strength require. In my improved method I draw a conical tube from a blank of metal and finish the same in a chuck provided with rolls corresponding to the ornamentations required.

In the drawings, A represents the drawn conical tube, and B the finished spun sheet-metal column.

C is the face-plate of my improved chuck, provided with the central extension, *e'*, by which it is secured to a rest or to the spindle of a lathe or other machine by which it can be turned. The extension *e'* is provided with a screw-thread, on which the collar *e* is screwed. In the face-plate C three slots are made radiating from the center to form ways, in which the dogs D D slide from and toward the center.

E is a ring, provided on its face with helical raised ways. This ring turns loose in a

groove formed on the rear of the face-plate C, and is held in place by the collar *e*. The dogs D D are provided with grooves, into which the helix on the ring enters, so that by turning the ring E in one direction the dogs D D are moved from the center outward, and when turned in the opposite direction the dogs are moved inward toward the center of the face-plate C. As the helix forms a regular and uniform volute, the dogs will be all drawn inward or outward uniformly, and are firmly held at any desired place without locking the operating-ring E.

Secured to the dogs D D are the slides F F, on the inner ends of which the spinning-rolls *g g* are journaled. To accurately adjust the same and to resist the radial strain on the rollers *g g*, the ends of the dogs D D are provided with a raised abutment, in which the adjusting-screws *d d* are threaded and which bear against the slides F F.

The operation is as follows: A conical tube, having been drawn, is placed on the spindle H and is subjected to a chuck provided with rollers *g g*, corresponding either with the bead *b*, the knob *b'*, the center *b''*, or with the whole of the configuration of the column, such as is shown in Fig. 7, or any other ornamental shape. By turning the operating-ring E, so as to bring the dogs D D and rollers *g g* to bear on the conical tube while the same revolves, the metal is gradually spun into the shape desired, and an ornamental column sharply finished is quickly produced, which requires no subsequent finishing by tools. I prefer to spin each of the ornamentations separately, as the length of the column is varied in the spinning, and therefore some ornaments, having deep corners, are difficult to produce at one operation.

A handle may be secured to the operating-ring E and a stop provided, against which the handle bears when the column or each ornamentation is completed. In this case, however, the work must be rotated while the chuck is stationary, and in most cases it is preferable to so revolve the work with the spindle H and bring the rollers *g g* to bear gradually on the same until the column is completed.

My chuck is specially intended for spinning

or swaging the columns of chain-swivels, but may be used for analogous purposes without departing from the spirit of my invention.

Having thus described my invention, I claim
5 as new and desire to secure by Letters Patent—

The combination of face-plate C, having extension, as described, the ring E, having helical raised ways, the dogs D, operated by said ring, the slides F, adapted to move in ways

in the face-plate, and spinning-rolls *g g*, carried by said slides, all the enumerated elements arranged to co-operate in a spinning-chuck, substantially as set forth.

JABEZ E. WALCOTT.

Witnesses:

M. F. BLIGH,

J. A. MILLER, Jr.